

# KMA333

## Automatic clip mounting machine

### Technical Data

|                                       |                   |
|---------------------------------------|-------------------|
| Min. window size, clear internal size | 330 mm x 330 mm   |
| Max. window size                      | 3500 mm x 2500 mm |

### Possible models

#### Clip mounting to frame or sash element

#### *High speed* (maximum) configuration

- with two freely movable portals
- and up to 8 clip-setting units
- two machining stations
- machining time: one setting cycle lasts 8 seconds (8 clips!)

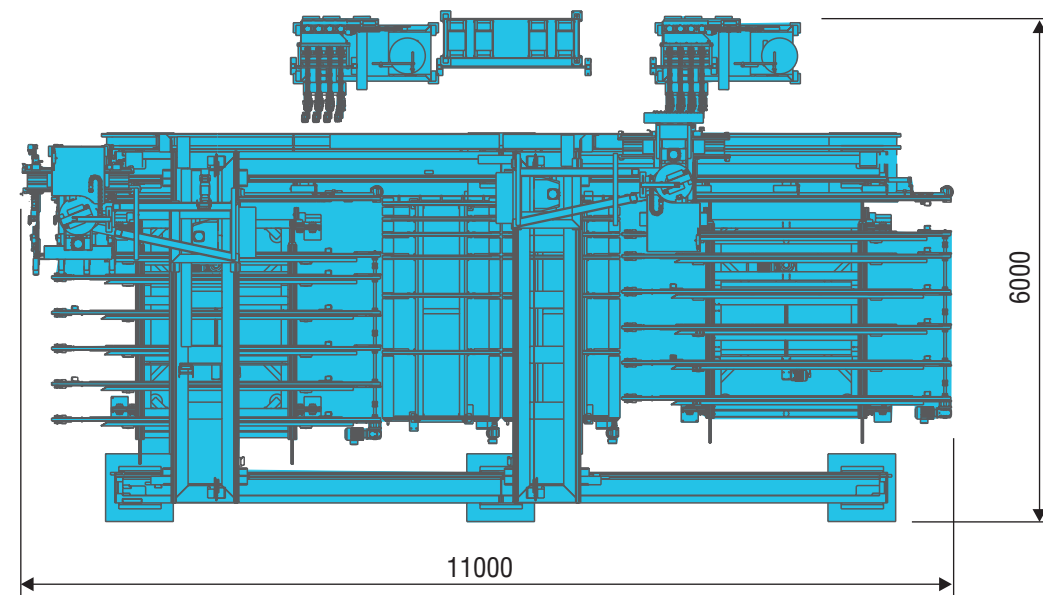

For sashes and frames  
made of wood

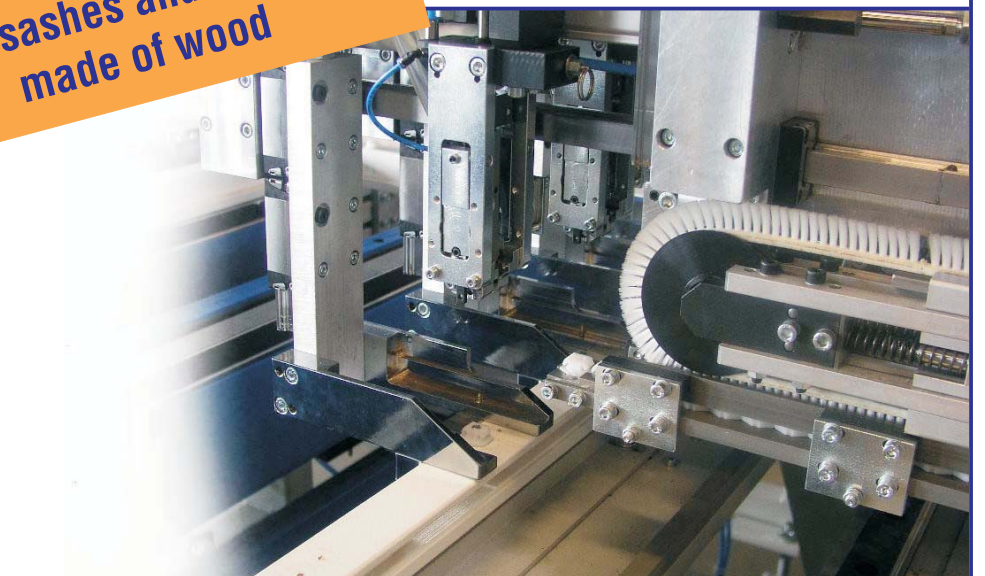

# KMA333

## Automatic clip mounting machine

998\_318 Prospekt KMA333\_englisch - Subject to technical modification.

# KMA333

## Automatic clip mounting machine

The **automatic clip mounting machines** of series **KMA333** set new trends towards the fully automatic final assembly of wooden windows. These systems offer high manufacturing flexibility and maximum precision at an optimum time management. All work, which is required for mounting the clips such as **singularising, setting and bolting**, is performed **fully automatically** and at **maximum precision** on the finished frame. This eliminates costly manual mounting work on frame structures that are difficult to handle and the risk of mounting errors. The automatic clip mounting machine has been designed for elements of various sizes. It is, of course, capable of mounting clips to transoms and crosses or of mounting several rows of clips to one frame piece.

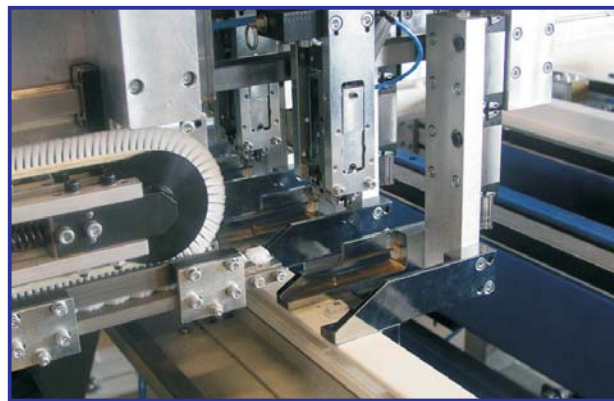

At the mounting station, the mounting head takes up in one operation all the clips that are required for the element to be machined. At the same time the frame is fed in via felt-covered belts and clamped. The mounting head is positioned at the respective frame piece and sets the clips. The number of clips to be attached at the same time depends on the number of setting units that thus define the machining time.

The system automatically calculates the distance between the clips in relation to the length of the frame piece. This ensures an optimum spacing of the clips. It is also possible to position the clips according to the specifications of the window manufacturing program. After all clips have been mounted to the element, the element is gently fed out via the felt-covered belts. While the clips are being mounted to the element, the clip transfer unit is filled with the clips that are required for the following element. Thus continuous operation without any waiting time is ensured.

### Mounting heads

The mounting head can be equipped with several clip-setting units that are capable of mounting various types of clips to the window element. Every setting unit is freely movable and positions itself separately - depending on the length of the frame piece - at the profile, ensuring thus the optimum spacing of the clips.



### Vibratory feeder with singularising mechanisms and conveyor belts

Vibratory feeders are used for the supply of clips. The clips are distributed by singularising mechanisms on the conveyor belts and transported to the head magazine. Vibratory feeders eliminate the manual loading of the magazines.

